

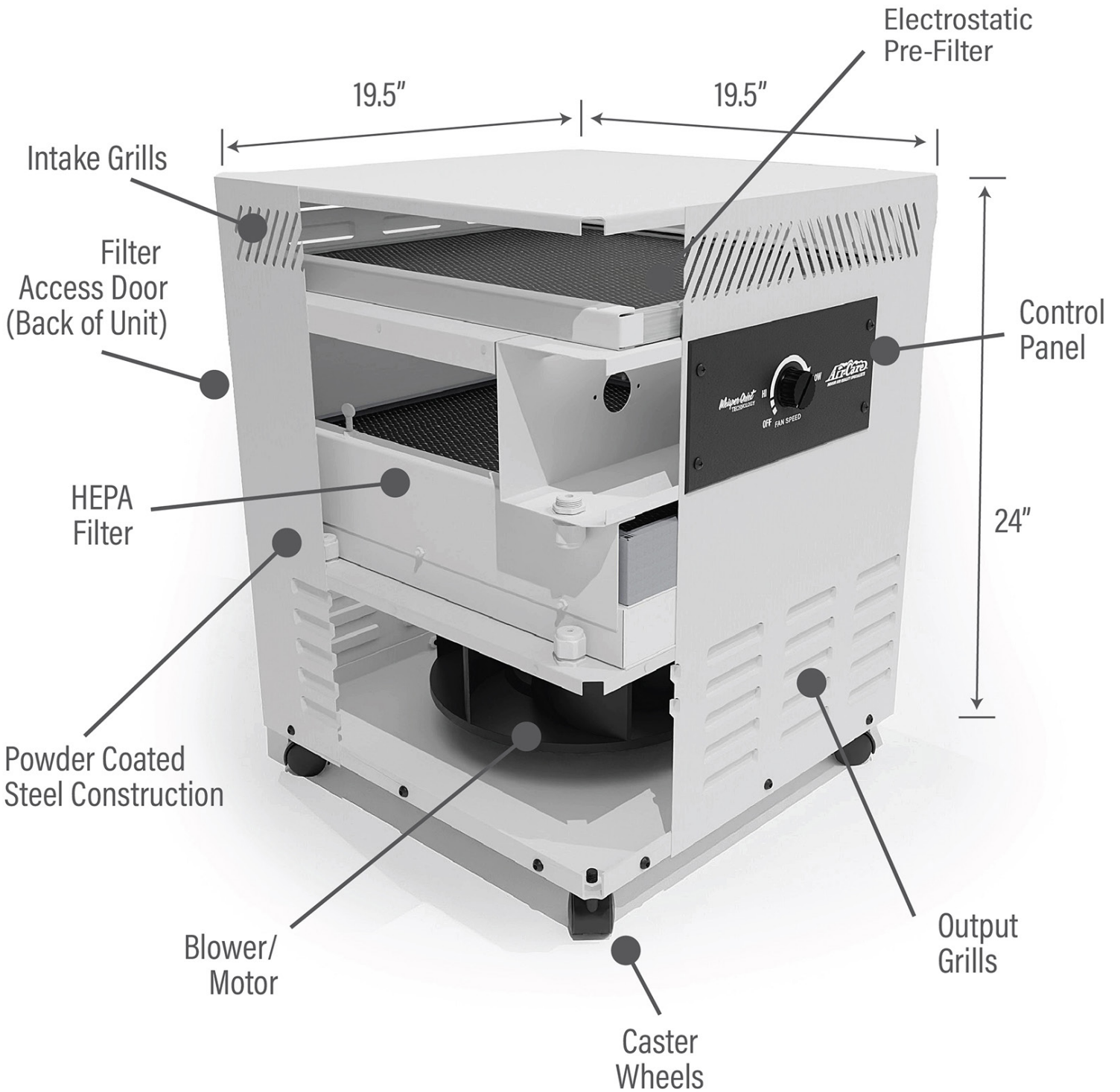

USER MANUAL



Part Number: FG0278

## TABLE OF CONTENTS

CHAPTER	PAGE
Unpacking	3
Filters	4
Safety Precautions/ Operating the Triton 440	5
Calculate Room Size	6
Purifier Maintenance	8
Triton 440 Specifications	9
Warranty	10

## UNPACKING & INSTALLATION INSTRUCTIONS

If there is any visible external damage to the pallet or box, note this on the shippers paperwork prior to accepting the delivery. If the contents of the pallet are visibly damaged, refuse to accept the shipment and advise Air-Care immediately. Remove the outer box and inspect for damage.

Report all damage immediately to your carrier. If special set-up instructions are required, they will be taped to the outside of the equipment or in the "Operating" section of this manual. Inspect all of the packing material for small parts before discarding packaging material.

### CHECK THAT ALL PARTS ARE PRESENT

1. Triton 440 main assembly. Wheels and wrench to attach them are included.
  2. 15' power cord
- Open the back door and check for the filters inside:**
3. Pre-Filter (5 extra filters are included)
  4. HEPA filter

## ATTACHING THE CASTER WHEELS

Packed inside the Triton is a bag with the caster wheels and wrench to attach the caster wheels to the unit. The Triton 440 is sturdy but use care when attaching the casters.

## FILTERS

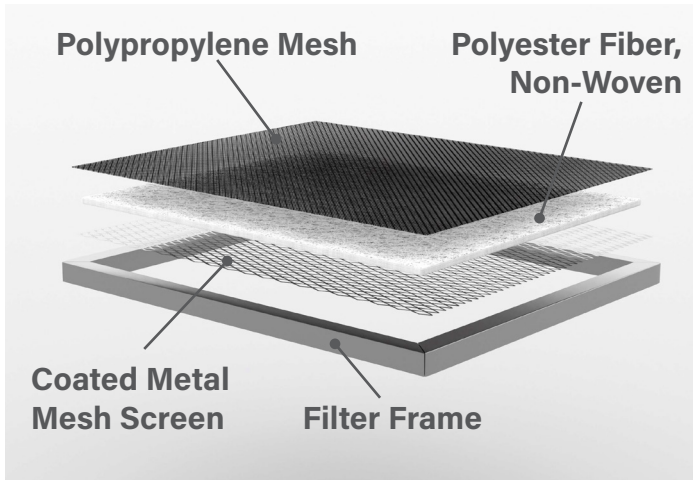

### Pre-Filter (16" x 19" x 1")

The pre-filter has three layers of cleaning. This filter collects most of the larger particles that enter the purifier.

**Polypropylene Mesh.** This captures many larger particulates using static electricity to capture the smaller particles.

**Polyester Fiber, Non-Woven.** This layer captures additional particles. (Part Number F0068)

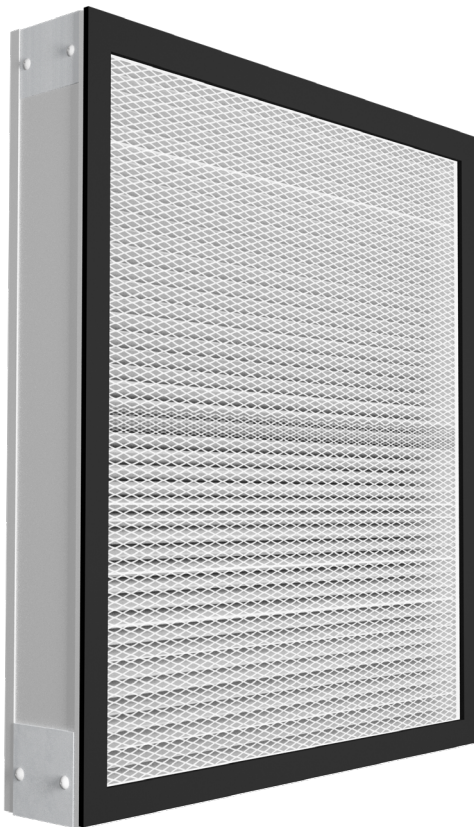

HEPA Filter

### HEPA Filter (16" x 19" x 2.5")

The HEPA Filter included in your purifier is a medical grade filter used in hospitals and other medical facilities due to its ability to remove 99.97% of dust, pollen, mold, and bacteria down to .3 microns. (Part Number F60189)

## SAFETY PRECAUTIONS

**ALWAYS** use safe and common sense precautions when working with Air-Care equipment. Do not block walkways with equipment. Remove delicate and breakable articles from the immediate work area. The following are precautions that should be reviewed by all persons who will be involved in the cleaning activity.

- Other than the filters, there are no user serviceable components in the Triton 440. Only trained technicians should attempt to make internal repairs on this equipment.
- Always turn off the main power switch on the control panel, or disconnect the power before opening or removing the back or removing the filters from the Triton 440.
- Be sure all power cords and electrical extensions are rated to meet or exceed the original Air-Care power cords (16 gauge), and inspect all AC power plug to be sure the Ground Pin is in place.
- Never connect power to Air-Care equipment unless all covers, and safety shields are in place. Mechanical and electrical parts.
- Never allow anyone except a properly trained technician to use the equipment or/and cleaning products.
- All Air-Care equipment is designed for US standard 115 volt, 60 Hz AC. Most Air-Care equipment can be special ordered to meet other worldwide standards for a reasonable price and delivery schedule. Always check the specifications on the equipment before connecting electrical power to Air-Care equipment. The Triton 440 can be special quoted for 220 Volt 50 Hz but may incur additional costs and may not provide the same performance as the 60 Hz model.

## OPERATING THE TRITON 440

### VERY IMPORTANT SAFETY INFORMATION

**DO NOT TURN ON THE**  
**TRITON 440 PURIFIER WITH THE ACCESS DOOR OPEN**

1. Place the unit in the desired location
2. Before operating the unit, check to see if the fan speed knob is in the OFF POSITION
2. Plug one end of the electrical cord to the socket in the back of the Triton 440
3. Place the other end of the electrical cord into an electrical outlet
4. Turn the speed knob clockwise to your desired fan speed setting.



## CALCULATE ROOM SIZE FOR EFFECTIVE PURIFICATION

**10'x10'x8'=800 CUBIC FEET=  
32 EXCHANGES OF AIR  
PER HOUR**

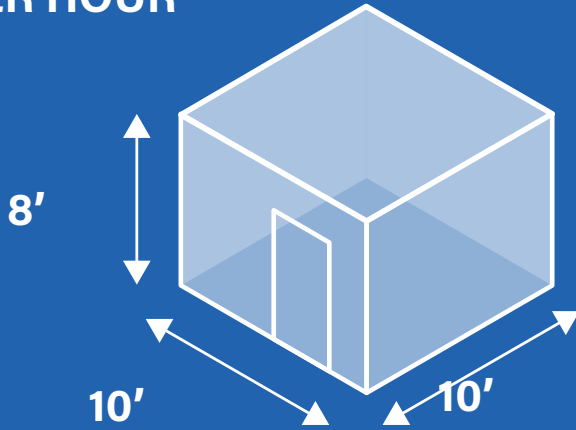

**20' X 40' X 8' = 6400 CUBIC  
FEET = 4 EXCHANGES OF  
AIR PER HOUR**

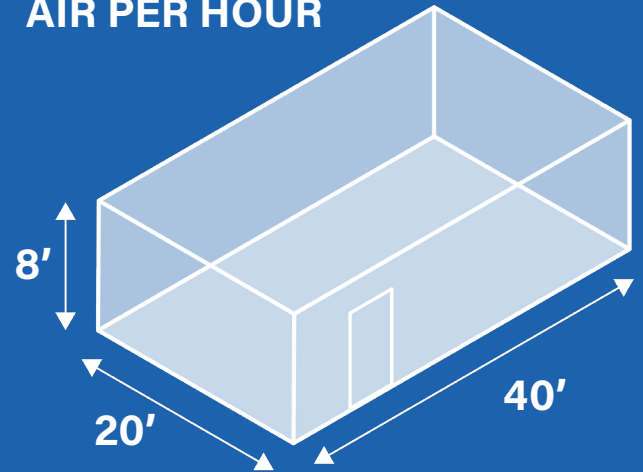

### AIR EXCHANGE BASED ON ROOM SIZE

The size and number of machines depends on the volume of the space being cleaned as well as how many Air Changes per Hour (ACH) are required by local regulation. As a starting point, calculate the square footage of the room or rooms, multiply by the ceiling height. It is generally recommended to have 3 to 4 air changes per hour in occupied areas

**SMALL ROOMS** 10' X 10' X 8' = 800 CUBIC FEET = 32 EXCHANGES OF AIR PER HOUR

**MEDIUM ROOMS** 20' X 20' X 8' = 3200 CUBIC FEET = 8 EXCHANGES OF AIR PER HOUR

**LARGE ROOMS** 20' X 40' X 8' = 6400 CUBIC FEET = 4 EXCHANGES OF AIR PER HOUR

**EXTRA LARGE ROOMS** 30' X 40' X 8' = 9600 CUBIC FEET = 3 EXCHANGES OF AIR PER HOUR

The Triton 440 circulates ambient air through its filter system and exhausts clean air into that environment.

The Triton 440 is small enough to be placed inconspicuously in a corner of a room or beside a piece of furniture and quiet enough to not hinder normal conversation.

Multiple units can be used in larger areas to distribute the filtration without requiring ducting in the room.

### WHEN SHOULD YOU CONSIDER USING ONE OR MORE OF THESE DEVICES?

There are only a few universal regulations or standards, but to say it is all guesswork is not at all true. On a construction site where large amounts of fine dust are generated, it would be expected that the workers would be wearing eye protection as well as some type of respirator to protect their lungs. If the site was adjacent to an office with a full staff, it would

be unthinkable to start the work without a temporary barrier of plastic sheeting to prevent the dust from covering the occupants and the office equipment. If the dust was potentially toxic and the particles were too small to be seen by the naked eye, even more protection for both the workers and the adjacent occupants would be required. This is the basic reason, it is necessary to filter the air in the work area, and to put that contaminated area in a "Negative Pressure" condition.

The size and number of machines depends on the volume of the space being cleaned as well as how many Air Changes per Hour (ACH) are required by local regulation. As a starting point, calculate the square footage of the room or rooms, multiply by the ceiling height. It is generally recommended to have 3 to 4 air changes per hour in occupied areas. To convert this requirement to a Cubic Feet per Minute (CFM) spec for the Air Purifier, multiply the Volume of the work area by 4 (or 3) changes/Hour then divide by 60 Minutes/Hour.

### **Length x Width x Height x 4 = cfm**

**60**

To calculate the required CFM to filter the air in a room that is 15 feet wide by 40 feet long with an 8-foot ceiling, plug in the size of the room in the formulas for either 3 or 4 air changes per hour (ACH)

$$4 \text{ ACH } \frac{15 \times 40 \times 8 \times 4}{60} = 320\text{cfm}$$

$$3 \text{ ACH } \frac{15 \times 40 \times 8 \times 3}{60} = 240\text{cfm}$$

$$4 \text{ ACH } \frac{15 \times 40 \times 11 \times 4}{60} = 440\text{cfm}$$

$$3 \text{ ACH } \frac{15 \times 40 \times 11 \times 3}{60} = 330\text{cfm}$$

As the filters become loaded, the effective cfm will drop slightly, so be sure you have a little more capacity than the minimum.

Air Purifiers may be required to circulate and filter the air within one or more of the contaminated areas to be collect contaminants as they are released into the air, as well as making certain there are no "dead spots" in the contained area where there could be a contaminate buildup.

# PURIFIER MAINTENANCE

## CLEANING THE OUTSIDE OF THE PURIFIER

The outside of your purifier should be cleaned occasionally with germicidal soap and water.

## THE PRE-FILTER

The prefilter/filter pad will most likely be the part that is contaminated the quickest as it traps larger particulates in the air.

## REPLACING THE FILTER PAD

It is recommended that you wear protective clothing and gloves as this filter will most likely be very dirty with captured contaminants.

1. Remove the polypropylene mesh
2. Remove the dirty pad and dispose
3. Insert new pad and return the polypropylene mesh.

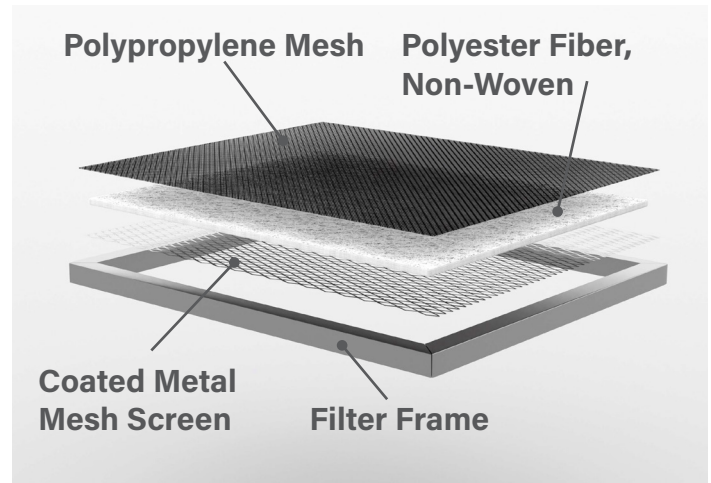

**REPLACEMENT FILTERS CAN BE  
PURCHASED FROM  
[WWW.AIR-CARE.COM](http://WWW.AIR-CARE.COM)  
OR TO FIND A RETAILER NEAR  
YOU CALL 800-322-9919**





Feature/Specification	Triton 440
Weight Lbs.	65
HEPA Filter (Multi-Stage)	99.97 @ 0.3 Microns (H13)
Pre-Filter	Multi-Layer Electrostatic
OZONE Free	YES
Energy Efficiency CFM/Watt	2.5
Input Power, 120 VAC	120 VAC
Wattage	180
Power Cord Length, w/ Ground Pin	Detachable 15 ft.
Number of Speeds	Continuously Variable
Motor HP	.20 HP
CFM with Filters	440
CFM Free Air	1250
Exhaust Air Location	4 Sides
Recommend HEPA Change	Yearly
Recommend Pre-filter Change	Replace 90-120 days with included Pads up to 18 months supply.
Sound Level dB	46-65
Dimensions	19.5 x 19.5 x 24
Casters	4 x 2" Locking Swivel
Construction	Powder Coated Steel
Air Changes Per Hour in 1,300 ft <sup>2</sup> x 8' = 10,400 ft <sup>3</sup>	2.5 ACH
Removes Particles Related to Allergies, Asthmas, etc.	YES
Made in USA	YES
Warranty	Limited Lifetime
Manufacturer Recommended Application	Healthcare Facilities, Schools, Offices, Homes
EPA OZONE FREE	YES
ETL/ UL	YES
CARB	YES
AHAM Verified (CADR)	YES
Energy Star	YES

\*E.P.A. Establishment Number: 96893-NV-1

Part # FG0189 HEPA 16" x 19" x 2.5"

Part # F0068 Replacement Pads 5 Pack 16x19



## LIMITED WARRANTY

### TRITON 440

Air-Care warrants this product to be free from defects in materials and workmanship to the original purchaser from the date of purchase.

<b>Motors</b>	<b>1 Year</b>
<b>Wheels</b>	<b>1 year</b>
<b>Consumables</b>	<b>Not Covered</b>

Warranty covers both parts and labor (labor is to be performed at Air-Care's facility located at 3868 E. Post Road, Las Vegas, Nevada).

Warranty is extended to the original purchaser and is not transferable.

This warranty does not extend to any damage to a product caused by or attributable to freight damage, abuse, misuse, improper or abnormal usage. Warranty is also void if the product has been modified or altered in any way.

The purchaser is responsible for the cost of shipping the equipment to Air-Care's facility for evaluation. If found to be defective and covered by the terms of this warranty, Air-Care will pay ground shipping charges on the repaired or replaced item back to the purchaser's location. Any additional expedited service charges for quicker shipping shall be born by the purchaser. If the product or component is not found to be a warranty issue, the purchaser will be responsible for return shipping charges.

Air-Care is not responsible or liable for indirect, special, or consequential damages arising out of or in connection with the use or performance of the product; damages with respect to any economic loss, loss of property, loss of revenues or profits, loss of use, or other incidental or consequential damages of whatsoever nature.

The warranty extended hereunder is in lieu of any and all other warranties, and any implied warranties of any type.

This warranty gives you specific rights. These rights and others vary from state to state.

**Division of D.P.L. Enterprises Inc.**  
**3868 East Post Road, Las Vegas, Nevada 89120, (702) 454-5515, FAX (702) 454-5225**  
**Website: [www.air-care.com](http://www.air-care.com); E-mail: [Info@Air-Care.com](mailto:Info@Air-Care.com)**